

5.37-07 SHOWN

5.35-07/5.37-07	P/N : 34282-101	SUBREV : N
DRAWN BY : C THOMSON	DATE : 08.06.08	SHEET 1 OF 6

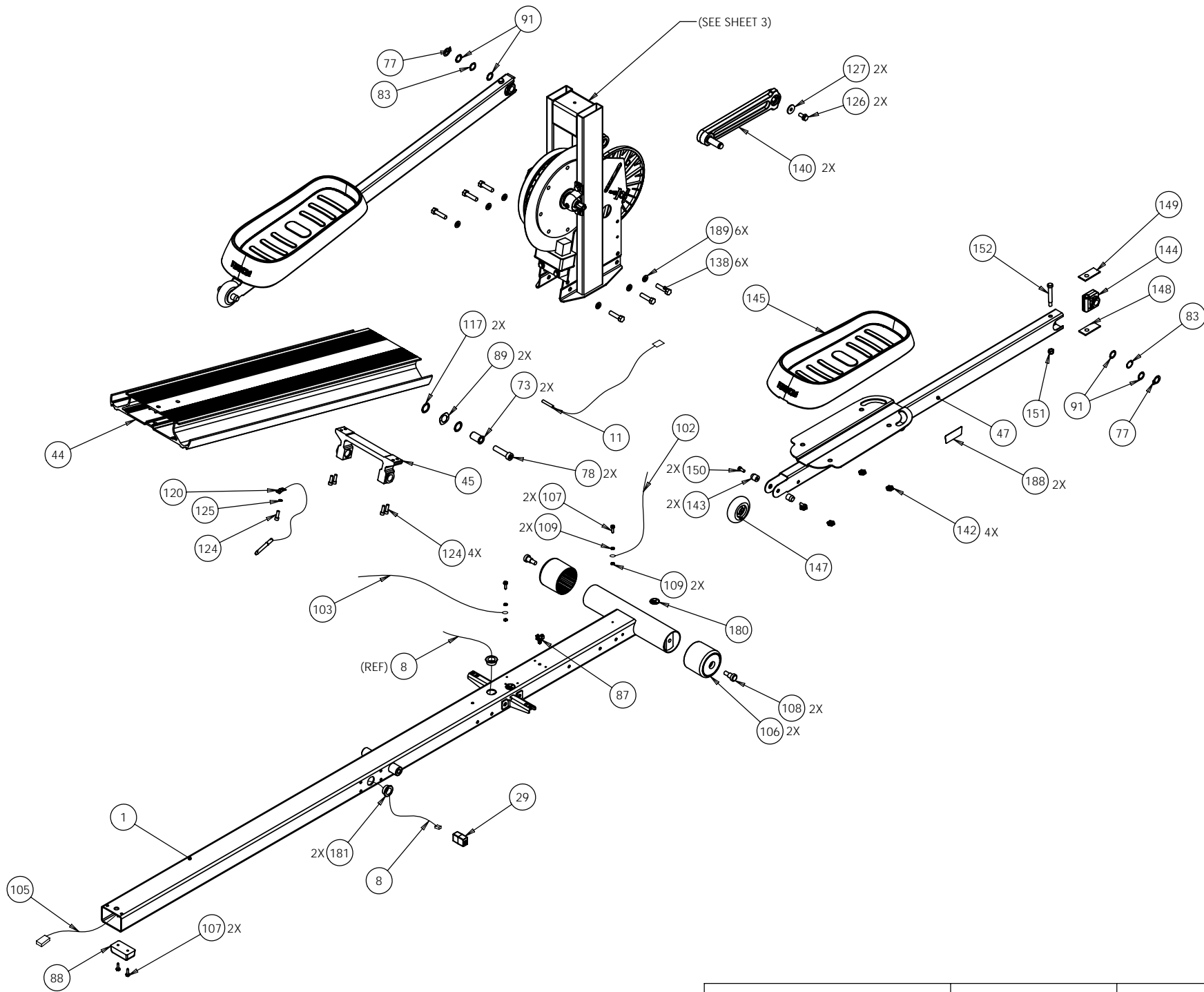

5.35-07/5.37-07	P/N : 34282-101	SUBREV : N
DRAWN BY : C THOMSON	DATE : 08.06.08	SHEET 2 OF 6

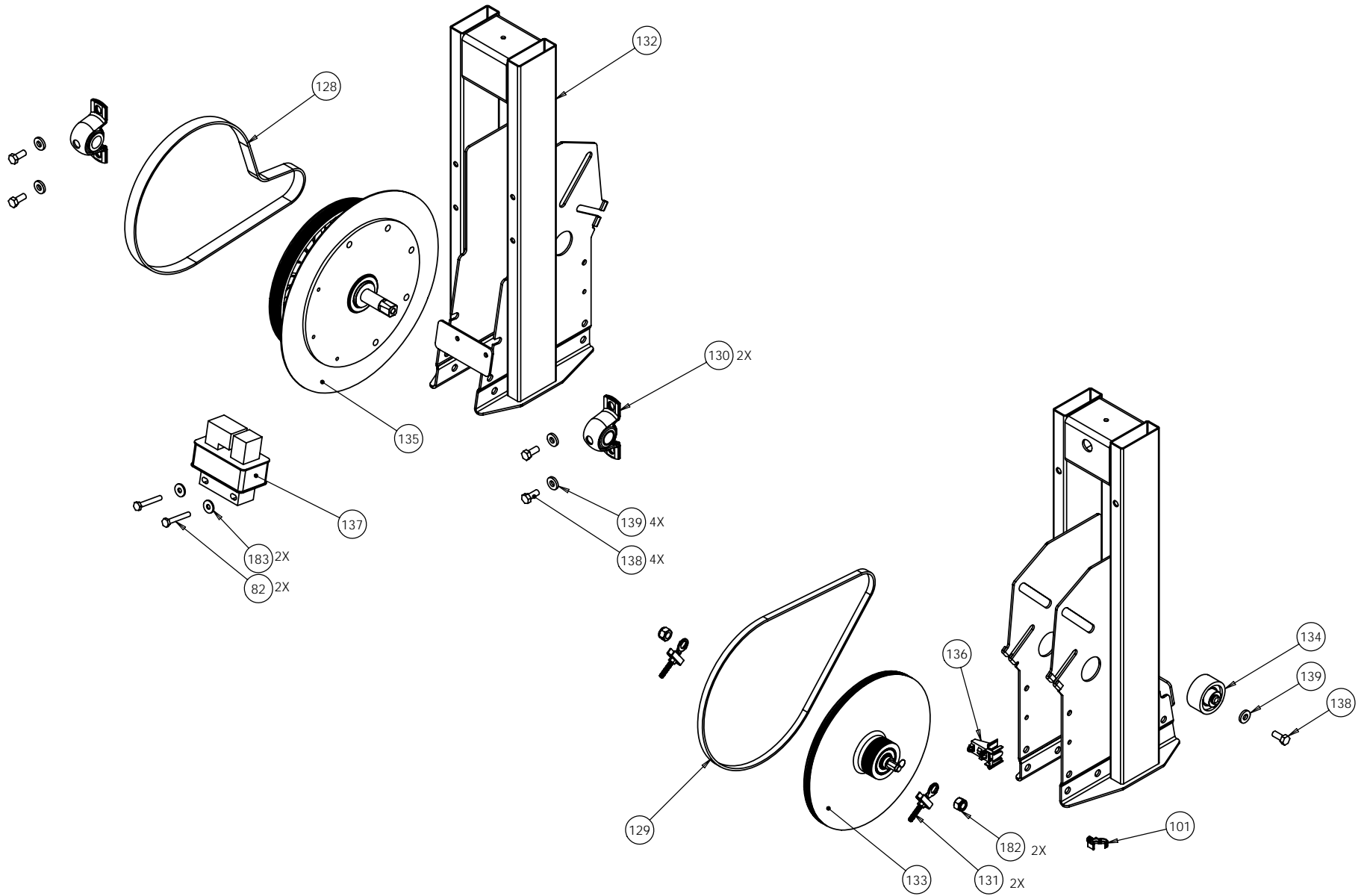

5.35-07/5.37-07	P/N : 34282-101	SUBREV : N
DRAWN BY : C THOMSON	DATE : 08.06.08	SHEET 3 OF 6

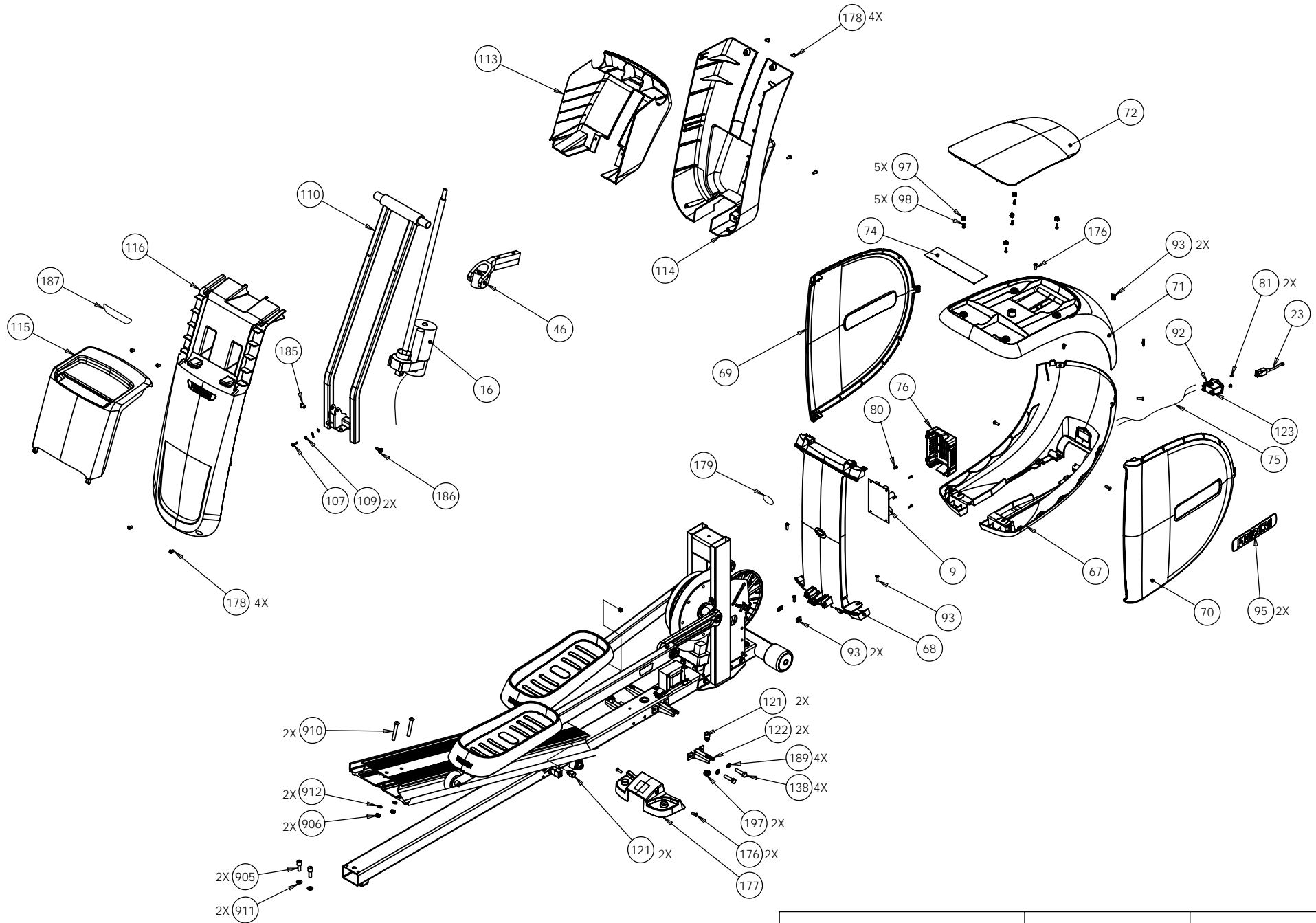

5.35-07/5.37-07	P/N : 34282-101	SUBREV : N
DRAWN BY : C THOMSON	DATE : 08.06.08	SHEET 4 OF 6

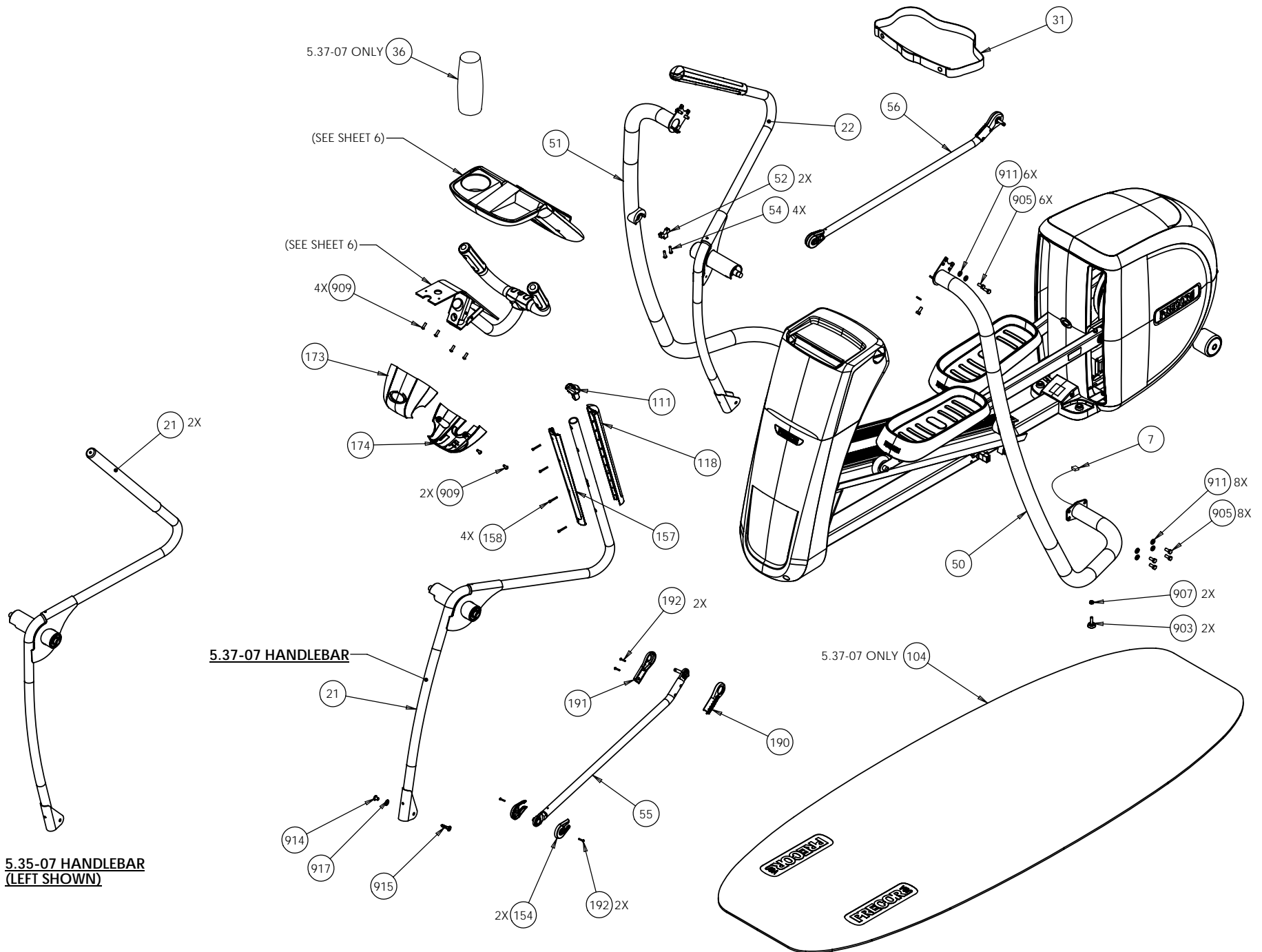

**5.35-07 HANDLEBAR
(LEFT SHOWN)**

5.37-07 HANDLEBAR

5.35-07/5.37-07	P/N : 34282-101	SUBREV : N
DRAWN BY : C THOMSON	DATE : 08.06.08	SHEET 5 OF 6

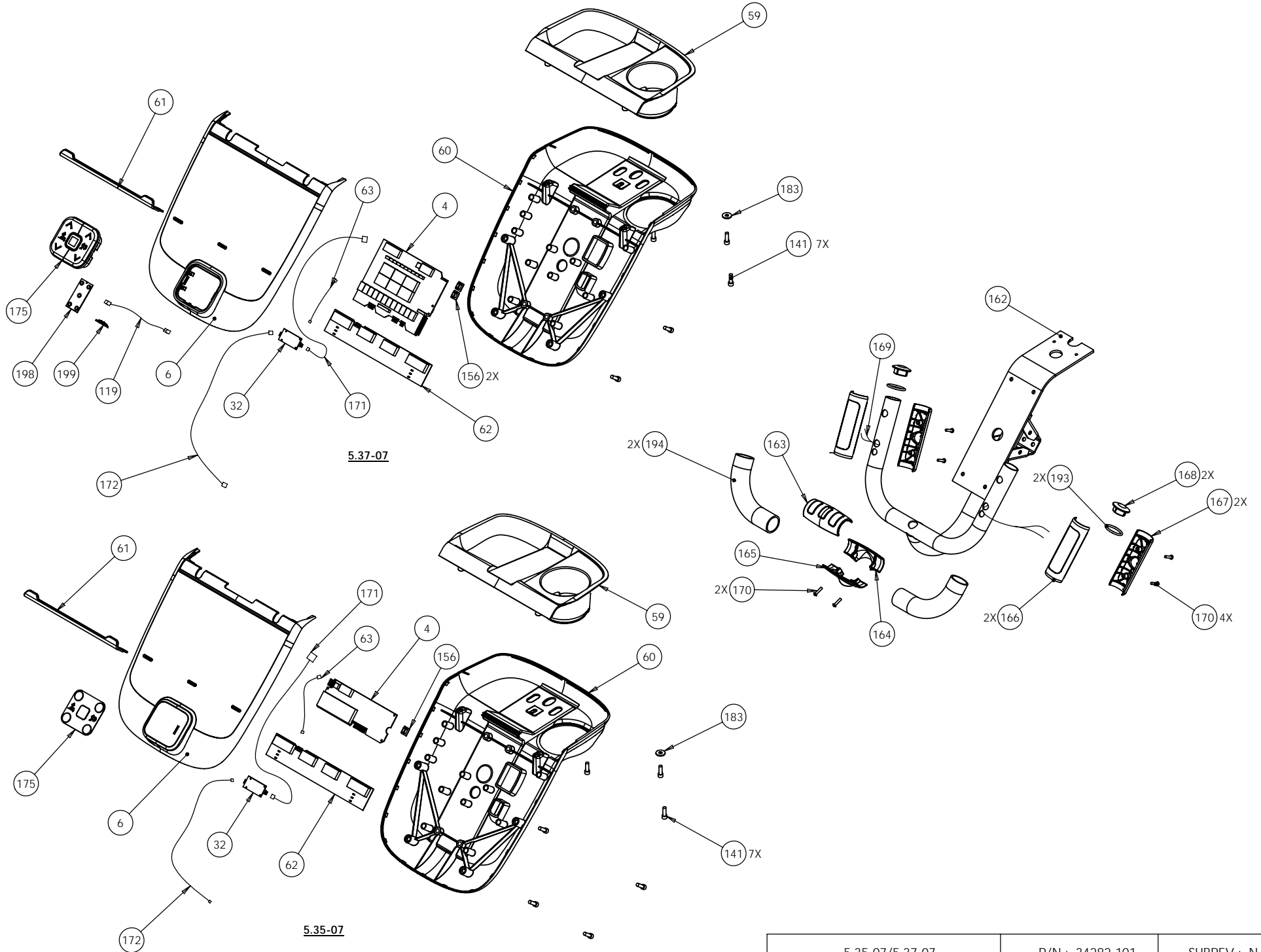

5.35-07/5.37-07	P/N : 34282-101	SUBREV : N
DRAWN BY : C THOMSON	DATE : 08.06.08	SHEET 6 OF 6

5.37 (serial code AYYR)

Part Number	Description	Bubble Number
PPP000000057034101	DISPLAY ASSEMBLY, 5.37-07	6
PPP000000044905042	ASSY,CBL,MOD,8P8C,1-1,42"	8
PPP000000034246101	ASSY, PCA & SW, EFX 5.3X-07, ARM LW	9.01
PPP000000049806036	ASSY, SPEED SENSOR, REED SWITCH, 03	11
PPP000000034119101	ACTUATOR, LIFT, CALIBRATED, W/O NUT	16
PPP000000034125103	ASSEMBLY, MOVING ARM, LEFT 5.37-07,	21
PPP000000034125104	ASSEMBLY, MOVING ARM, RIGHT, 5.37-0	22
PPP000000010392111	POWER CORD,125VAC,10A,8.0 FT	23
PPP000000034229400	SW,EFX 5.3X-07,ARM LWR,V4.00	27
PPP000000011415102	COUPLER,MOD,8P8C,INLINE,SNAP-IN	29
PPP000000038819103	TRANSMITTER, POLAR T34, HEARTRATE,W	31
PPP000000049401102	BOARD, CHR & WIRELESS, SALUTRON	32
PPP000000034252101	WATER BOTTLE, NALGENE, W/PRECOR LOG	36
PPP000000034123101	ASSEMBLY, CROSSRAMP, ALPINE	44
PPP000000049992101	RAMP, LIFT, PIVOT BRACKET, ALPINE,A	45
PPP000000057042101	YOKE REPLACEMENT KIT, 5.31, 5.33, 5	46
PPP000000034151101	WELDMENT, STAIRARM RAIL, PAINTED, U	47
PPP000000034171107	WELDMENT, SIDE TUBE, LEFT, PAINTED,	50
PPP000000034171108	WELDMENT, SIDE TUBE, RIGHT, PAINTED	51
PPP000000034299101	ASSEMBLY, LOWER LINK, LEFT, 5.35-07	55
PPP000000034299102	ASSEMBLY, LOWER LINK, RIGHT, 5.35-0	56
PPP000000034189101	PLASTIC, DISPLAY ACCESSORY TRAY, AL	59
PPP000000034190101	BACK PANEL, DISPLAY, ALPINE	60
PPP000000048712103	BOOK SUPPORT, DISPLAY-C, MAKROBLEND	61
PPP000000048947153	ASSY, PCA & SW, DISPLAY-C, METRICS,	62
PPP000000049800004	ASSY,CABLE, 6C,.1 CTR,1-1,TIN, W/FE	63
PPP000000010123105	CABLE TIE, 6 LONG,WHITE,NYLON	64
PPP000000034180101	COVER, DRIVE, BOTTOM, ALPINE	67
PPP000000034221103	ASSEMBLY, DRIVE COVER, FRONT	68
PPP000000034222101	ASSEMBLY, DRIVE COVER, SIDE, LEFT	69
PPP000000034222102	ASSEMBLY, DRIVE COVER, SIDE, RIGHT	70
PPP000000034223101	ASSEMBLY, DRIVE COVER, TOP	71
PPP000000034224101	ASSEMBLY, DRIVE COVER, ACCESS PANEL	72
PPP000000034313101	SLEEVE, RAMP PIVOT	73
PPP000000034269102	LABEL, WIRING DIAGRAM, 5.3X-07	74

PPP00000044435032	ASSY,CBL,2-COND,18AWG,32",QK DISC	75
PPP00000047774103	COVER, LPCA, 5.3X	76
PPP00000AAHN063003	RING, RETAINER, 5/8, EXTERNAL	77
PPP00000CAGE050200	SCREW,SKHD,1/2-13X2.00,BLK OXIDE	78
PPP00000MGCN016038	SCREW,MCH,8-32X3/8,PANHD,PHIL,	80
PPP00000MNCN013031	SCREW, MCH,6-32X5/16,FLTHD,PHIL	81
PPP00000HCCN025175	SCREW,HEX,GR 5,1/4-20X1.75, ZN	82
PPP00000WAGNN062001	WASHER, WAVE, .87 OD X .62 ID	83
PPP000000010136103	CLIP,U TYPE, TINNERMAN, 1/4-20	84
PPP000000012515101	CLAMP, CABLE, BLACK, RELEASABLE ON	87
PPP000000031074103	FOOT, FIXED, SP TREAD	88
PPP00000WAGSN072001	WASHER, WAVE .1.05 O.D., .755	89
PPP00000WNNN063001	WASHER, FLT, 5/8X.880X.010	91
PPP000000037436101	LABEL, CHASIS NEUTRAL	92
PPP000000010136103	CLIP,U TYPE, TINNERMAN, 1/4-20	93
PPP000000012223250	FUSE,TIME-DELAY,2.5A,250V,5X20MM	94
PPP000000035733101	BADGE, PRECOR, 9.3X-07/5.2X-07	95
PPP000000034207101	ANCHOR, ACCESS PANEL	97
PPP00000PMTN016050	SCREW,TCS,#8X1/2,PHIL,BLK SHARPERIZ	98
PPP000000012515101	CLAMP, CABLE, BLACK, RELEASABLE ON	101
PPP000000044437005	CBL,1C,18AWG,#10 RING/187X032 QD RE	102
PPP000000044437018	ASSY, CABLE, GND,RING/QK DISC,18"	103
PPP000000045109078	ASSY,CBL,LPCA TO LIFT,78"	105
PPP000000045742101	WHEEL,846/842	106
PPP00000PKCN019075	SCREW,S/T,#10X.75,WSHHXHD,ZN	107
PPP00000RATN038050	SCREW,SHLD,3/8 X 1/2 ,HEXSC,BLK SH	108
PPP00000WAMCN019002	WASHER, LOCK, EXT TOOTH, #10	109
PPP000000034111101	WELDMENT, LIFT SUPPORT, MOVING ARMS	110
PPP000000039844103	CAP, HANDGRIP, AMAZON STONE	111
PPP000000034185101	COVER, LIFT, TOP, ALPINE	113
PPP000000034186101	COVER, LIFT, BACK, ALPINE	114
PPP000000034188101	MAG RACK, LIFT COVER, ALPINE	115
PPP000000034219103	ASSEMBLY; LIFT COVER; FRONT	116
PPP00000WNNN081003	WASHER,FLT,1.188-1.0X.027,STL	117
PPP000000039845202	FRONT, HANDGRIP, OVERMOLDED, AMAZON	118
PPP000000011476102	PIN, RING, LOCKOUT	120
PPP000000034306101	RECEIVER, PIN, QUICK DISCONNECT	121

PPP00000034138101	BRACKET, LINK STOW/REAR COVER, PAIN	122
PPP00000034276101	ASSEMBLY, POWER ENTRY MOD/NEUTRAL L	123
PPP00000CATN025075	SCREW,SKHD,1/4-20 X 3/4,BLK SHARPER	124
PPP00000WATNN025002	WASHER, LK-INT, ID=.25,	125
PPP00000HRWE031075	SCREW, SERRATED FLANGE HD, HEX, NYL	126
PPP00000WNNN032009	WASHER,FLT, .321X1.00X.090 THK	127
PPP000000010217130	BELT, DRIVE, POLY V (DAYCO 27-0628)	128
PPP000000010217131	BELT, DRIVE, POLY V (DAYCO 27-0627)	129
PPP000000011245104	BUSHING,HEAVY DUTY PILLOW BLK	130
PPP000000012866101	ASSEMBLY, BANJO BOLT, WASHER, AND N	131
PPP000000034161101	WELDMENT, DRIVE, PAINTED, ALPINE	132
PPP000000034213101	ASSEMBLY, STEP-UP PULLEY, ALPINE	133
PPP000000038320104	IDLER,PULLEY	134
PPP000000044300103	ASSY, DRIVE INPUT, RETAIL	135
PPP000000047553102	RETAINER, SENSOR	136
PPP000000047888102	ELECTROMAGNET,EC BRAKE,.093" 2 POS	137
PPP00000HCCN031075	SCREW, HEX HD, GRADE 5, 5/16-18 X .	138
PPP00000WBANN034013	WASHER,FLAT,ID=11/32,OD3/4,TH=.125,	139
PPP000000034168101	ASSY, CRANK ARM, ALPINE	140
PPP00000CACN025075	SCREW, SKHD, 1/4 X 0.75, ZN	141
PPP000000012647101	PALNUT, SELF THREADING NUT, REG. TY	142
PPP000000034206103	RETAINER, STAIR ARM, BLACK	143
PPP000000038301101	ASSY,PIVOT BLOCK	144
PPP000000039750103	FOOT PEDAL, ALPINE	145
PPP000000039874101	DOUBLE ADHESIVE FOAM TAPE 1" X 4"X1	146
PPP000000048337101	ASSY, STAIRARM WHEEL, CONSUMER EFX,	147
PPP000000048340101	SPACER, RAIL, URETHANE	148
PPP000000048340102	SPACER, RAIL ,URETHANE, RED	149
PPP00000CEGN006014	SCREW, SKHD, M6 X 14, BLK OXIDE	150
PPP00000KDTN031025	LOCKNUT, FULL, 5/16-18,BLK SHARPERI	151
PPP00000RANN031200	SCREW,SHLD,5/16 X 2,HEXSC	152
PPP000000047023102	COVER, LINK, FRONT, ALPINE	154
PPP000000010123102	CABLE TIE, 3-7/8 LONG,WHITE,NYL	155
PPP000000012264101	RJ-45 TELEPHONE JACK PLUG	156
PPP000000039846202	BACK, HANDGRIP, OVERMOLDED, AMAZON	157
PPP00000CCNN016113	SCREW,SKHD,8-32X1.125L,SS	158
PPP000000034141101	WELDMENT, DISPLAY SUPPORT WITH HAND	162

PPP00000034208101	COVER, HHR ACCESS HOLE	163
PPP00000034226101	COVER, HHR ACCESS HOLE, TOP	164
PPP00000034226102	COVER, HHR ACCESS HOLE, BOTTOM	165
PPP00000042713102	HHR SENSOR, TOP	166
PPP00000042714102	HHR SENSOR, BOTTOM	167
PPP00000042730101	PLUG, HHR, HANDLE BAR END	168
PPP00000048421032	ASSY, CABLE, HHR GRIP, W/SHIELD, 32	169
PPP00000TCNN016075	SCREW, BTHD, 8-32X.75, SS	170
PPP00000035796019	ASSY, CABLE, HHR TO DISPLAY, 19"	171
PPP00000049893018	ASSY, CBL, HSG TO MINI-FIT REC, 4P4C, 1	172
PPP00000034210101	COVER, DISPLAY BRACKET, TOP	173
PPP00000034210102	COVER, DISPLAY BRACKET, BOTTOM	174
PPP00000034215101	ASSY, D-PAD, 5 POSITION, ICON, EFX,	175
PPP00000035754008	ASSY, CABLE, 6C, 1-1, MOLEX KK, TIN	176
PPP00000TFTN025075	SCREW, BTHD, 1/4-20X3/4, BLK SHARPERIZ	176
PPP00000034275104	ASSEMBLY, WEDGE/DECALS	177
PPP00000TFTN025075	SCREW, BTHD, 1/4-20X3/4, BLK SHARPERIZ	178
PPP00000034204101	BADGE, REAR COVER, EFX, ALPINE	179
PPP00000033984101	LABEL, SAFETY, GROUND SYMBOL	180
PPP00000010178107	BUSHING, SNAP	181
PPP00000KMCN044038	NUT, HEX, 7/16-14, ZN	182
PPP00000WACN025008	WASHER, FLAT, 1/4 X .080	183
PPP00000FAGN025028	NUT, CONNECTOR, JOINT	185
PPP00000FBGN025091	BOLT, CONNECTOR, JOINT, 29/32 LONG	186
PPP00000034205101	BADGE, LIFT COVER, PRECOR, ALPINE	187
PPP00000034265102	DECAL, LINK ATTACHMENT, STAIR ARM 5	188
PPP00000WBCN031007	WASHER, FLT, 5/16X.688X.065, ZN	189
PPP00000034211101	COVER, LINK END, TOP, ALPINE	190
PPP00000034211102	COVER, LINK END, BOTTOM, ALPINE	191
PPP00000MGTN013075	SCREW, MCH, 6-32X3/4, PANHD, PHIL, BLK S	192
PPP00000010115113	O-RING, ROUND, 1.25ID X .139	193
PPP00000034277101	GRIP; HANDLEBAR; EXTRUDED VINYL, 6.75	194
PPP00000034266101	DECAL, LINK ATTACHMENT, COVER, LEFT	195
PPP00000034267101	DECAL, LINK ATTACHMENT, COVER, RIGH	196
PPP00000KRCN050031	NUT, HEX THIN, UNF, 1/2-20, ZINC	197
PPP00000049003401	PCA, SNAPDOME D-PAD	198
PPP00000049805101	D-PAD PCA LOCK CLIP	199

PPP00000011095109	ENDCAP,HEYCO (2633DOM)	201
PPP00000034230102	LITERATURE KIT, EFX5.37-07	999